



**7004**

# CHD / CFA MACHINE OPERATORS MANUAL



The information contained in this manual is specific to the 7004 CHD / CFA machine as shown above. The machine is equipped with a 25Tm rotary head and was commissioned in September 2005.

This information is supplementary to that contained in the Site Piling Manual and does not replace or modify the procedures in the Site Piling Manual in any way whatsoever.

## **CE Marking Information**

Location of CE plate on machine:

Machine Designation: 7004

Intended Piling System: Continuous Flight Auger /  
Continuous Helical Displacement

Gross Weight (kg): 58 tonnes

Rated Power (kW): 560 kW (760 hp) @ 2100 rpm

Year of Manufacture: 2005

# Table of Contents

<b>CE Marking Information .....</b>	<b>3</b>
<b>1. General description. ....</b>	<b>5</b>
<b>2. Technical Specification .....</b>	<b>6</b>
<b>3. Hydraulic system .....</b>	<b>7</b>
<b>4. Winch system.....</b>	<b>7</b>
<b>5. Dimensions.....</b>	<b>8</b>
<b>6. Starting the machine.....</b>	<b>11</b>
<b>7. Rigging the machine for work.....</b>	<b>12</b>
<b>8. De-rigging the machine for transport.....</b>	<b>13</b>
<b>9. Loading &amp; unloading the machine from the trailer .....</b>	<b>14</b>
<b>10. Inspection and maintenance.....</b>	<b>15</b>
<b>11. Machine controls .....</b>	<b>18</b>
<b>12. Hydraulic and electric diagrams.....</b>	<b>20</b>
<b>13. Hydraulic parts list.....</b>	<b>21</b>

# Table of Figures

<b>Figure 1: Machine side view .....</b>	<b>8</b>
<b>Figure 2: Machine rear view.....</b>	<b>9</b>
<b>Figure 3: Machine in transport configuration .....</b>	<b>10</b>
<b>Figure 4: Description of high pressure filters .....</b>	<b>16</b>
<b>Figure 5: Cab control layout. ....</b>	<b>18</b>

## **1. General description.**

The machine is designed to be a dual purpose CHD / CFA machine which utilises a purpose designed 25Tm rotary head. The head is designed to operate at 15 rpm at full torque and 55 rpm at minimum torque, the maximum torque can be set by modifying the hydraulic motors on the head. This means we can alter the output torque of the rotary head whilst retaining the same engine output. This is necessary as running the engine at low output for long periods can damage the engine.

The machine is built on an Akerman H16D base which has been almost totally modified. The chassis has been extended to accommodate the larger Cummins QSK19-760 (760 HP) diesel engine and remote radiator. The front end of the machine is also modified to accept our own design of boom, spreader, mast etc. The mast is designed to allow it to articulate 5 degrees side to side and 5 degrees forward. This enables the machine to attain mast verticality on slightly undulating piling mats.

## 2. Technical Specification

- Gross Weight (without augers and cleaner) 58 Tonnes
- Operating length 10.5m
- Operating height 24.3m
- Operating width 3.3m
- Transport length (not including trailer) 12.9m
- Transport height (not including trailer) 3.8m
- Mast articulation – Fore & Aft 5°
- Mast articulation – Side to Side 5°
  
- Base Machine Akerman H16D
- Length of track on ground 4.05m
- Track Gauge 2.4m
- Track plate width 0.9m
- Ground Pressure  
Average Static Pressure 78.1kN m<sup>-2</sup>  
*(See FPS Working Platform Sheets available from Plant Dept for specific data)*
  
- Noise level in Cab 78 dB
- Noise level at pile centre line 80 dB
- Noise level at rear of the machine 87 dB
- Operating Ambient temperature range -5°C - 40°C

### 3. Hydraulic system

- Prime Mover Cummins QSK19-760
- Power 760kW @ 2100 rpm
- Maximum Head Torque 250kNm
- Maximum Head Speed 55 rpm
- Maximum Depth Capacity 20m CHD  
19m CFA
- Maximum Auger Diameter 700mm
- Instrumentation Jean Lutz 'Taralog'
- Hydraulic Pressure 275 Bar
- Hydraulic Flow

Pumps 1, 2 & 3	3 x 300 l/min (Rotary head)
Pumps 4 & 5	2 x 205 l/min (Tracks)
Pump 6	1 x 173 l/min (Slew + additional services)
Pump 7	1 x 57 l/min (Pilot pump + oil cooler)
Pump 8	1 x 40 l/min (Engine radiator fans)

### 4. Winch system

- Main winch type CH230 c/w ??m of Ø20 rope
- Maximum line pull 10 tonnes
- Maximum extraction force 40 tonnes
- Handling winch type PD12C c/w 65m of Ø16 rope
- Maximum line pull 5 tonnes

## 5. Dimensions

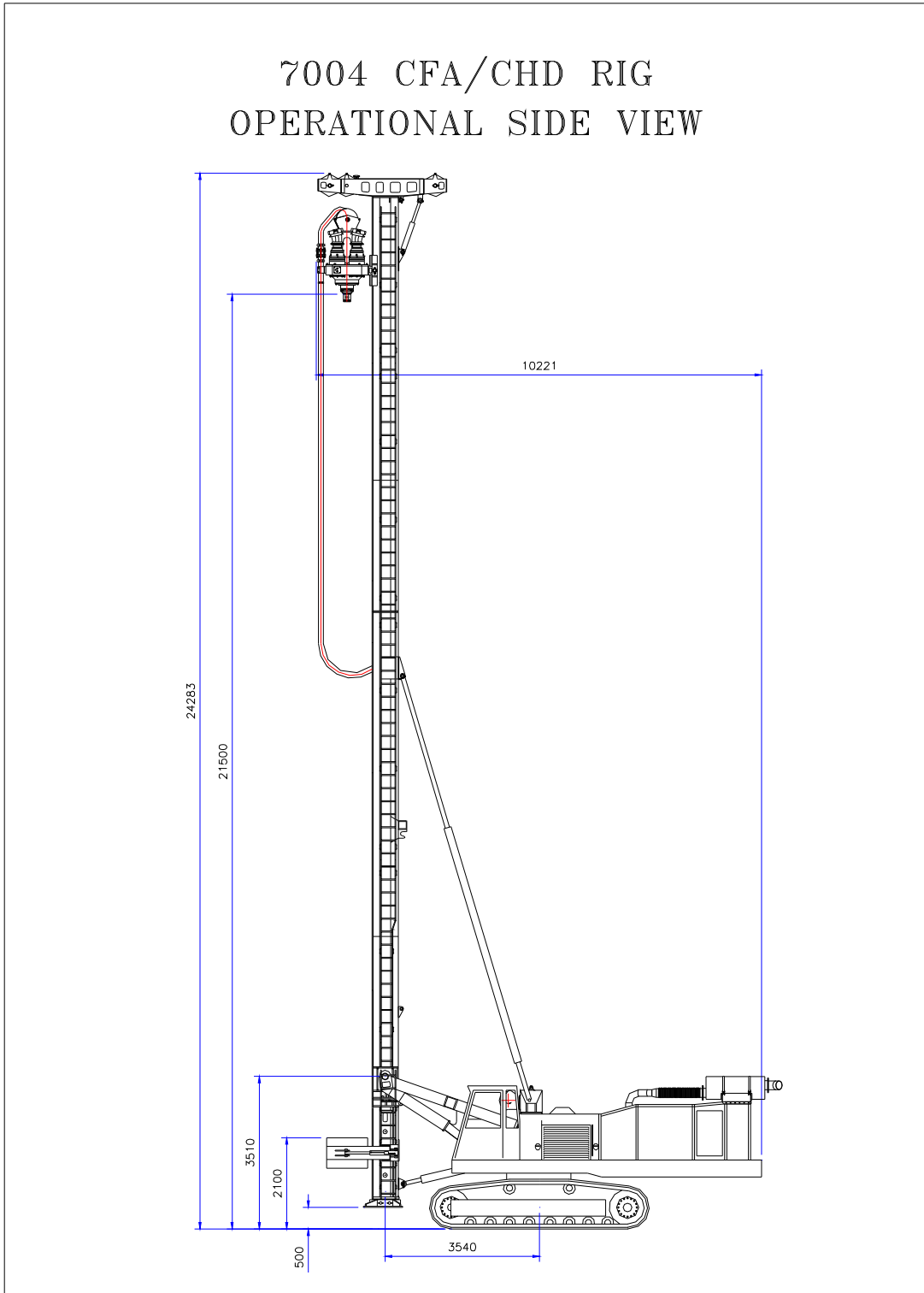

**Figure 1: Machine side view**

7004 CFA/CHD RIG  
OPERATIONAL REAR VIEW

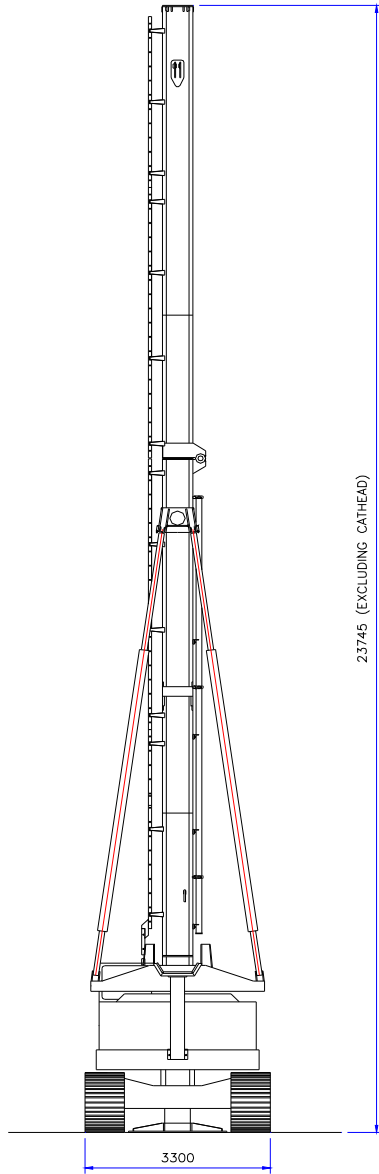

**Figure 2: Machine rear view**

7004 CFA/CHD RIG  
TRANSPORT VIEW

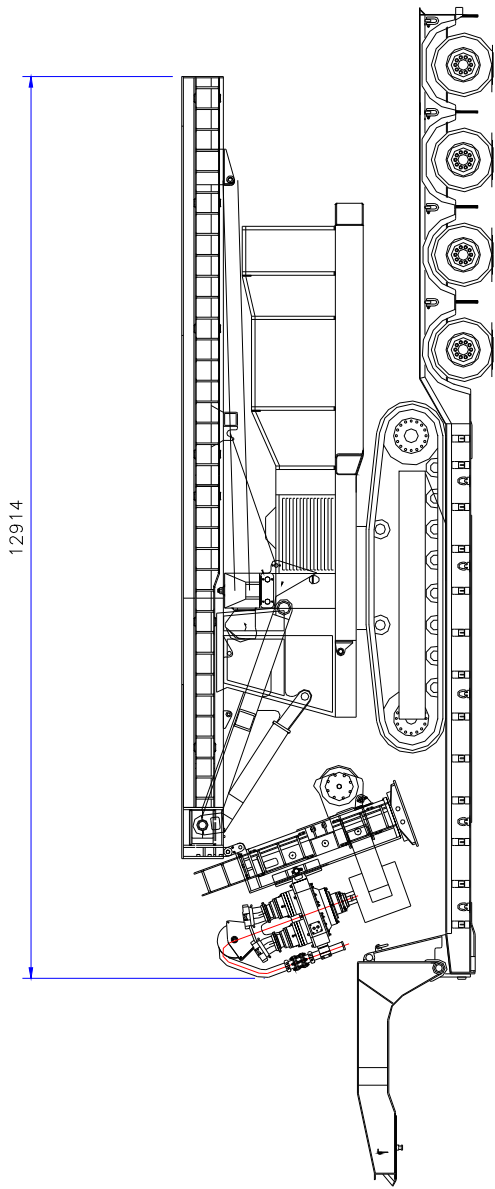

**Figure 3: Machine in transport configuration**

## **6. Starting the machine**

- Fit and turn the isolator lever located on the filter bracket behind the 3<sup>rd</sup> door from the rear on the driver's side.
- Check that all emergency stops are in the un-depressed condition
- Ensure no cab controls are accidentally being moved.
- Turn the ignition key located on the ignition panel (see figure 5)
- Allow the engine to warm up for approximately 10 minutes

## 7. Rigging the machine for work.

- With the engine running depress the hydraulic system start button. (Figure 5).
- Position the machine on level ground, in an area with sufficient room for erecting the machine. Ensure the area is clear of over head cables etc.
- Unbolt the mast transport bracket and unfold the mast by pushing with the fork lift, take care not to strain the hinge by lifting the mast with the forks.
- Bolt the mast joint together using a suitable ladder and harness. Do not walk along the mast.
- Position the stabiliser cylinder so that approximately 300mm of rod protrudes. Lock in position using flow control valve.
- Fully retract the foot cylinder
- Set the engine revs at approximately 1500rpm
- Switch the Local / Remote switch to Remote. (Figure 5)
- With the pendant control fully extend the cathead cylinder then fully extend the erection cylinders, ensuring that the winch ropes, safety rope and depth wire are free.
- Once the mast disengages the assist cylinders, turn the assist cylinders taps to the off position, this will keep them in the correct place ready for de-rigging.
- Switch the Local / Remote switch to local.
- Extend the raking cylinders ensuring that the mast remains centrally positioned about the machine centre line, as deviation from this can cause serious damage.
- Take care as the upper and lower sections come together. Make sure that the dowels are correctly located.
- Whilst retaining pressure on the raking cylinders and the stabiliser cylinder, secure the joint using the screws provided.
- Note: The machine should not be used until all the screws are fitted, all bolts must be grade 12.9 Socket Head Cap Screws.
- Connect the depth wire.

## 8. De-rigging the machine for transport.

- With the engine running depress the hydraulic system start button. (Figure 5).
- With the mast vertical lock the stabiliser cylinder in position using the flow control valve under the operator's seat.
- Position the rotary head so that the weight is taken on its lower stops.
- Position the rotary head hydraulic pipes and concrete pipes in the jaws of the auger gate, to keep them from dragging on the floor.
- Disconnect the depth wire.
- Remove all of the screws from the mast joint.
- Set the stabilising cylinder to show approximately 300mm of extended rod.
- Set the engine revs to approximately 1500rpm.
- Close the raking cylinders ensuring that the mast remains centrally positioned about the machine centre line, *as deviation from this can cause serious damage.*
- Ensure the assist cylinders are fully extended.
- Switch the Local / Remote switch to Remote. (Figure 5).
- With the pendant control fully close the erection cylinders until the mast re-engages with the assist cylinders, open the assist cylinder taps and continue to lower onto the mast rest.
- Fully close the cathead cylinder, ensuring that the winch ropes, safety rope and depth wire are free.
- Unbolt the upper hinge using a suitable ladder and harness. Do not walk along the mast.
- With the fork lift push the mast into the closed position, take care not to strain the hinge by lifting it with the forks. Secure in the transport position using the bracket provided.
- Secure any loose ropes and hoses
- Switch the Local / Remote switch to local.

## 9. Loading & unloading the machine from the trailer

The machine can be safely loaded and unloaded from the trailer when the machine is fully folded for transport.

Do not attempt to load or unload the machine in any other configuration

The machine should be loaded by reversing it onto the bed of a low loader as shown in the photograph below.



The machine should be chained down to the bed of the low loader via the tie down points as fitted using suitably sized chains and shackles. If possible the machine should be chocked to prevent any forward movement during heavy braking.

## **10. Inspection and maintenance.**

The following inspection should be carried out each working day.

Check the engine oil level, hydraulic oil level, fuel level and battery acid level, replenish as necessary.

Check for leaks in the fuel and hydraulic systems and rectify if due to loose pipe fitting. In the case of more serious leaks or persistent leaks contact the Plant Department.

Check for scuffing, impact or crushing damage to the hydraulic hoses and the concrete hoses, pay particular attention to the rotary head hoses, organise for a replacement before failure.

Check that the hydraulic filter tell-tale has not popped out of any of the 8 filters. These are located behind the 3<sup>rd</sup> door from the rear and are positioned 4 per side. If the tell-tale on any of the filters has popped out, then with the oil at working temperature, adjust the engine speed to full and re-set it. If it immediately pops back out then the filter element is in need of immediate replacement.

See below for details of filter element length and micron rating.

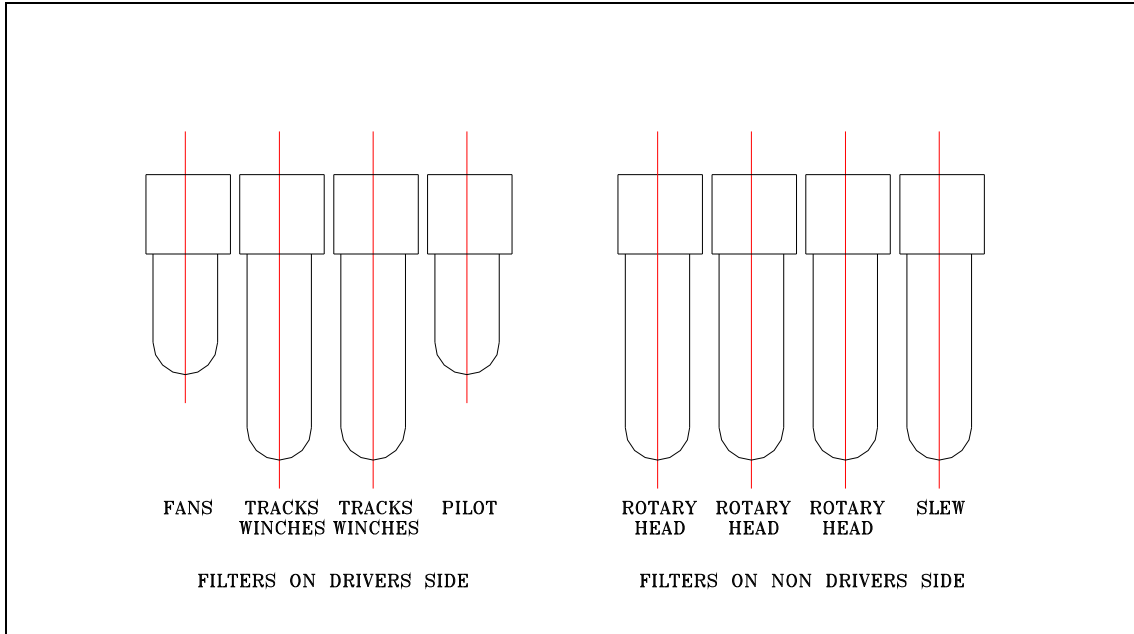

**Figure 4: Description of high pressure filters**

DESCRIPTION	ELEMENT LENGTH	MICRON RATING	PALL CODE
ROTARY HEAD	13"	6μ	H9600KNTH
ROTARY HEAD	13"	6μ	H9600KNTH
ROTARY HEAD	13"	6μ	H9600KNTH
SLEW	13"	6μ	H9600KNTH
TRACKS / WINCHES	13"	6μ	H9600KNTH
TRACKS / WINCHES	13"	6μ	H9600KNTH
PILOT	4"	6μ	H9600KNRH
FANS	4"	6μ	H9600KNRH

Check the winch ropes for kinks and broken strands and replace if necessary. Also check the rope anchors and winch mountings for security.

Pump grease into the following grease nipples.

- Raking cylinders
- Erection cylinders
- Assist cylinders
- Cathead cylinder
- Stabiliser cylinder
- Rotary head labyrinth seal
- Concrete pipe couplings
- Mast Pivot Pin
- Mast Pivot trunion blocks
- Mast – foot slider
- Door hinges

At the same time check carefully for any signs of wear, cracking or other damage to the main frame, mast, boom, spreader, cathead etc. Pay particular attention to the raking cylinder mountings, the mast hinge and pivot as these are under constant load.

Check that the rotary head carriage slider bolts are tight.

Check that the spreader beam bolts are tight.

If inspection reveals any problem whatsoever, contact Plant Department immediately.



Table 1. List of Cab controls, to be read in conjunction with Figure 6 above.

Item	Description
1	Auger Cleaner raise
2	Auger Cleaner lower
3	Track forward
4	Track backward
5	Slew brake
6	Winch Freefall
7	Main control panel
8	Ignition panel
9	Throttle
10a	Right rake extend & left rake extend
10b	Left rake extend
10c	Left rake extend & right rake retract
10d	Right rake retract
10e	Right rake retract & left rake retract
10f	Left rake retract
10g	Left rake retract & right rake extend
10h	Right rake extend
11a	Track direction joystick (left)
11b	Track direction joystick (right)
12a	Handling winch joystick (lower)
12b	Handling winch joystick (raise)
13a	Foot Down
13b	Foot down / slew clockwise
13c	Slew clockwise
13d	Slew clockwise / foot up
13e	Foot up
13f	Slew anticlockwise / Foot up
13g	Slew anticlockwise
13h	Slew anticlockwise / Foot down

Item	Description
14	Boom Raise
15	Boom Lower
16	Rotary head forwards
17	Rotary head forwards (speed control)
18	Rotary head reverse
19	Rotary head reverse (speed control)
20	Rotary head STOP
21	Winch manual raise
22	Winch manual raise (speed control)
23	Winch auto raise
24	Winch auto raise (speed control)
25	Winch manual lower
26	Winch manual lower (speed control)
27	Winch freefall
28	Winch STOP
29	Horn
30	Rotary head torque control switch
31	System ON
32	System OFF
33	Gates open
34	Gates closed
35	Auger cleaner auto / manual switch
36	Auger cleaner height selector switch (auto only)
37	Assist on / off
38	Pendant on / off

## Pendant

Item	Description
39	Erect up
40	Erect down
41	Cathead up
42	Cathead down
43	Stabiliser in
44	Stabiliser out

## **12. Hydraulic and electric diagrams**

The following A3 sheets contain the above diagrams and should be read in conjunction with the hydraulic parts list and the hydraulic system notes document (provided separately with this manual).

### 13. Hydraulic parts list

Item	Description	Hose Size
1	Service winch proportional control lever, 2 way, 1 off Hamworthy: PRSV-S01-X-018-F0	Inlet: 3/8" Tank: 3/8" Outlets: 1/4"
2	Raking cylinder proportional control lever, 4 way, 1 off Hamworthy: PRSV-C01-X-005-F0	Inlet: 3/8" Tank: 3/8" Outlets: 1/4"
3	Main winch pilot control valve, 1 off Rexroth: 4WE10J/3X/CG24N9K4 Subplate, 1 off, Rexroth: G66/01	Inlet: 1/2" Tank: 1/2" Service ports: 3/8"
4	Pilot & cooling fan flow divider, 50:50, 1 off Integrated Hydraulics: 2CFD250-8W-6W-95-S	<i>Inlet: 3/4"</i> Outlets: 1/2"
5	Filter, Pilot & cooling fan, 6µm, 1 off Pall: HH9680C20KNRBP	Inlet: 3/4" Outlet: 3/4"
6	Pilot and cooling fan pump, 1 off Samhydraulik: H1C-030-S-FP1-D-M-NBR	Suction: 1" Outlet: 3/4"
7	Filter assembly, track pumps and slew pump, 6µm, 3-off Pall: HH9680C20KNTBP	Inlet: 1" Outlet: 1"
8	Track pumps, 2-off Samhydraulik: H1V108-S-F2-S-EM-2-24V-0/108-M-NBR	Suction: 2 1/2" Outlet: 1" Pilot: 1/4"
9	Slew pump, Samhydraulik: H1V108-S-F2-S-PC-1-250bar-0/90-M-NBR	Suction: 2 1/2" Outlet: 1"
10A	Additional services control block, 5 way Hydrocontrol: HC-D20/5-IR009(260)-AG06 W002A-H005-RPG06-01PA(150)01PB(150) [W001A-H005-RPG06-01PA(150)01PB(150)] x 4 TMNG07	Inlet: 1"  Tank: 1"  High pressure carry-over: 1" 1 <sup>st</sup> service: 3/4" 2 <sup>nd</sup> to 5 <sup>th</sup> service: 1/2"
10B	Additional services control block, 6 way Hydrocontrol: HC-D20/6-IR009(260)-AG06 [W001A-H005-RPG06-01PA(150)01PB(150)] x 2 [W002A-H005-RPG06-01PA(150)01PB(150)] x 3 [W001A-H005-RPG06-01PA(150)01PB(150)] x 1 TMNG07	Inlet: 1" Tank: 1" High pressure carry-over: 1" All services: 1/2"
11	Pilot released check valve, main winch bypass, Integrated Hydraulics: 4CK350-10W-S	Inlet: 1" Outlet: 1" Pilot: 3/8"
12	Check valve, main winch bypass, Rexroth: S25A1	Inlet: 1" Outlet: 1"
13	Shuttle valve, main winch brake release, 1 off Integrated hydraulics: 1SH25-3W-S	Inlets: 3/8" Outlet: 3/8"
14	Main Winch, 1 off Braden: CH230A-36090-01	Inlet: 1 1/4" Outlet: 1 1/4" Brake pilot lines: 3/8"
15	Filter assembly, rotary head pumps, 6µm, 3-off Pall: HH9680C20KNTBP	Inlet: 1 1/4" Outlet: 1 1/4"

16	Rotary head pumps, 3-off Samhydraulik: H1V226-S-F2-S-EM-2-24V-0/188-M-NBR	Suction: 3 1/2" Outlet: 1 1/4" Pilot: 1/4"
17	Rotary head relief and dump valves, 2-off Denison: R4V10-535-10-09-24DC-A1	<i>Subplate mounted: n/a</i>
18	Rotary head forward/off/ reverse valve, 1 off Parker: D11-1VW-2C5-JP	Subplate mounted: n/a
19	Rotary head motors, 2 off plus 2 off Rexroth: A6VM200-HD1/63W-VAB020B Rexroth: A6VM200-HD1/63W-VAB020DB	Inlet: 1 1/4" Outlet: 1 1/4" Drain: 3/4"
20	Service winch, 1 off Braden: PD12C-59039-05	<i>Inlet: 3/4"</i>  <i>Outlet: 3/4"</i>
21	Main winch float valve, 1 off Rexroth: 4WE6JB/6X/AG24N9K4 Subplate, 1 off, Rexroth: G341/01	Inlet: 3/8" Tank: 3/8" Service ports: 3/8"
22	Rotary head return flow bypass cooler, 1 off (Part of Bearwards radiator package)	Inlet: 3/4" Outlet: 3/4"
23	Mast erect control valves, 2 off Rexroth: 4WE10C/3X/CG24N9K4 Subplates, 2 off, Rexroth: G66/01	Inlet: 1/2" Tank: 3/8" Service ports: 1/2"
24	Engine cooling fan pump, Salami: 2PB11.3/11.3D-P52S2-UA1	Suction: 3/4" Outlet: 1/2"
25	Engine cooling fan relief valve, Integrated hydraulic: 1AR66-P-4W-35-S	<i>Inlet: 1/2"    Outlet: 1/2"</i> Drain: 1/2"
26	Engine cooling fan motors, 2-off Parker/Voac: F11-010-MB-CN-K-000	Inlet: 1/2"    Outlet: 1/2" Drain: 1/4"
27	Filter assembly, engine cooling fan, 6µm, 1 off Pall: HH9680C20KNRBP	Inlet: 1/2" Outlet: 1/2"
28	Rotary head control manifold, 1 off Roger Bullivant: A1 102723	Inlets: 1 1/4"    Tank: 2" Service ports: 2" Gauge tappings: 1/4"
29A	Rake cylinder, indivisible from item 29B, 1465 stroke, 2-off Fox: 180M-2x4565	<i>Both ports: 1/2"</i>
29B	Erect cylinder, indivisible from item 29A, 3100 stroke, 2 off Fox: 180M-2x4565	
30	Motion control valve, part of items 29A & 29B, 8 off Sun: CBEA-LHN	Cartridge: n/a
31	Boom cylinder, 150 stroke, 2-off Fox: 200M-5x150	<i>Both ports: 1/2"</i>
32	Motion control valve, part of item 31, 4 off Sun: CBEA-LHN	Cartridge: n/a
33	Assist cylinder, 1485 stroke, 2-off Fox: 150M-5x1485	<i>Both ports: 3/8"</i>
34	Motion control valve, part of item 33, 4 off Sun: CBEA-LHN	Cartridge: n/a
35	Flow divider & synchroniser (50:50) for erect cylinders, 1 off Cartridge, Sun: FSES-XAN Body, Sun: PMW	Inlet: 1/2" Outlets: 1/2"
36	Gate cylinder, 2-off Fox: 80M-25x420	Both ports: 3/8"
37	Motion control valve, part of item 36, 4 off Sun: CBEA-LHN	Cartridge: n/a

38	Cathead cylinder, 1 off Fox: 100M-27x475	Both ports: 1/2"
39	Motion control valve, part of item 38, 2 off Sun: CBEA-LHN	Cartridge: n/a
40	Stabiliser cylinder, Fox: 150M-13x1285	Both ports: 1/2"
41	Pilot valves to operate items 10A & 10B, 8 off Rexroth: 4WE6J/5X/AG24NK4	Subplate mounted: n/a
42A	Side ported manifold block for 2 off items 41, 2 way, 1-off  BEP: 10561/2	Inlet: 3/8" Tank: 3/8" Service ports: 1/4"
42B	Side ported manifold block for 6 off items 41, 6 way, 1-off BEP: 10561/6	Inlet: 3/8" Tank: 3/8" Service ports: 1/4"
43	Pilot pressure reducing valve, 1 off Integrated hydraulics: 1PD25-P-3W-6-S	Inlet: 3/8" Outlet: 3/8" Drain: 3/8"
43A	Pilot pressure reducing valve, 1 off Integrated hydraulics: 1PD25-P-3W-2-S	Inlet: 3/8" Outlet: 3/8" Drain: 3/8"
44	Main pilot relief and dump valve, 1 off Integrated hydraulics: 7VR150-P-4W-20-1-H24-S	Inlet: 1/2" Tank: 1/2"
45	Proportional pressure valve for head torque control, 1 off Amca: MDM-5-30-24V c/w subplate A-5-DM-1	Inlet: 3/8" Outlet: 3/8" Drain: 3/8"
46	Main winch brake pressure reducing valve, 1 off Integrated hydraulics: 1PDC25-P-3W-12-S	Inlet: 3/8" Outlet: 3/8" Drain: 3/8"
47	Not used	
48	Not used	
49	Auger cleaner drive motor, 1 off XXX:	Inlet: 1/2" Outlet: 1/2" Drain: 3/8"
50	Air compressor motor, 1 off Rexroth: A2FM32/6.1WVPBB040	Inlet: 1/2" Outlet: 1/2" Drain: 1/4"
51	Not used	
52	Slew and foot control joystick, 4 way, 1 off Hamworthy: PRSV-C01-X-022-F0	Inlet: 3/8" Outlets: 3/8" Drain: 3/8"
53	Manual shut-off valve, ¼ turn ball type, 2 off (assist cyl)	Both ports: 3/8"
53A	Manual shut-off valve, ¼ turn ball type, 3 off (stabilising cyl + auger cleaner bypass)	Both ports: 1/2"
54	Pressure compensated flow control valve to limit slew speed, 2 off, Flupac: SRVR-16	Inlet: 3/4" Outlet: close coupled
55	Foot cylinder, 1 off Fox: 200M-4x1000	Both ports: 3/4"
56	Foot motion control valve, remote mounted, 1 off Integrated Hydraulics: 1CEE350-F-10W-35-S-3	All ports: 3/4"
57	Winch brake bleed valve, 1 off Flupac: SRVR-10	Inlet: 3/8" Outlet: 3/8"
58	Auger cleaner over centre valve, 1-off Integrated Hydraulics: 1CEER95-F-4W-35-S-4	All ports ½" or 3/8"?